



ENGINE

Model	: Mercedes-Benz OM 926 LA
Type	: D926.929 EU Stage 3A
No. Of Cylinders	: 6
Displacement	: 7200 cc
Net Power	: 140 - 160 kW (187 HP - 214 HP) 2200 rpm
Gross Power	: 150 - 172 kW (201 HP - 230 HP) 2200 rpm
Max torque	: 1000 Nm (1300 rpm)

TRANSMISSION

- Powershift (planetary gear, electro hydraulically actuated) with 8 speeds for both forward and reverse

DIFFERENTIAL AND FINAL DRIVE

- Double-reduction by spiral bevel and planetary gears with operator controlled hydraulically lock/unlock differential.

FRONT AXLE

Oscillation	: 15° Left or Righth (Total 30°)
Wheel lean	: 20° Left or Righth (Total 40°)
Ground Clearance	: 595 mm

BRAKES

Service Brakes	: Air-actuated, multi disc oil cooled on all four rear wheels
Parking Brake	: Spring-engaged, air disengaged multi disc oil cooled on T/M output shaft

TIRES

- 14,00-24-16 PR (G-2)

HYDRAULIC SYSTEM

Circuit	: Closed-center system, with load sensing using electro-hydraulic valve.
Oil pump	: Variable-displacement piston pump
Capacity	: 192 l/min
Max. Working Pressure	: 172 bar
Steering Circuit	: 25 cm ³ /rev

BLADE

Type	: Wear resistant steel, with box section reinforcement with hydraulic side shift.
LengthxHeightxThickness	: 3710 mm x 610 mm x 19 mm
Max. Blade Lift Above Ground	: 525 mm
Circle turning angle	: 360°
Max. Bank Cutting Angle	: 90°
Cutting angle	: 39° to 85°

PERFORMANCE (Speeds)

Forward	: 1 st	4	km/h
	: 2 nd	5,4	km/h
	: 3 rd	8,2	km/h
	: 4 th	11,2	km/h
	: 5 th	16	km/h
	: 6 th	21,6	km/h
	: 7 th	32,9	km/h
	: 8 th	45,2	km/h
Reverse	: 1 st	3,7	km/h
	: 2 nd	5,0	km/h
	: 3 rd	7,6	km/h
	: 4 th	10,5	km/h
	: 5 th	15	km/h
	: 6 th	20,3	km/h
	: 7 th	30,9	km/h
	: 8 th	42,4	km/h
Minimum Turning Radius	: 6,9 m		

DIMENSIONS

Overall length	: 11106 mm (With front blade and rear ripper)
	: 10188 mm (With front weight and rear ripper)
	: 8944 mm (Without any attachment)
Overall width	: 2440 mm
Overall height	: 3400 mm
Wheelbase	: 6250 mm
Ground Clearance	: 380 mm

WEIGHT

18.470 Kg
With 14,00-24-20PR tires, rear mounted ripper, front push block, T/M belly guard, operator, Air-Con., ROPS/FOBS Cab., 1/2 tank diesel and lighting/mirrors etc. for road registration.

HMK 600MG

Dimensions (I)

Unit: mm

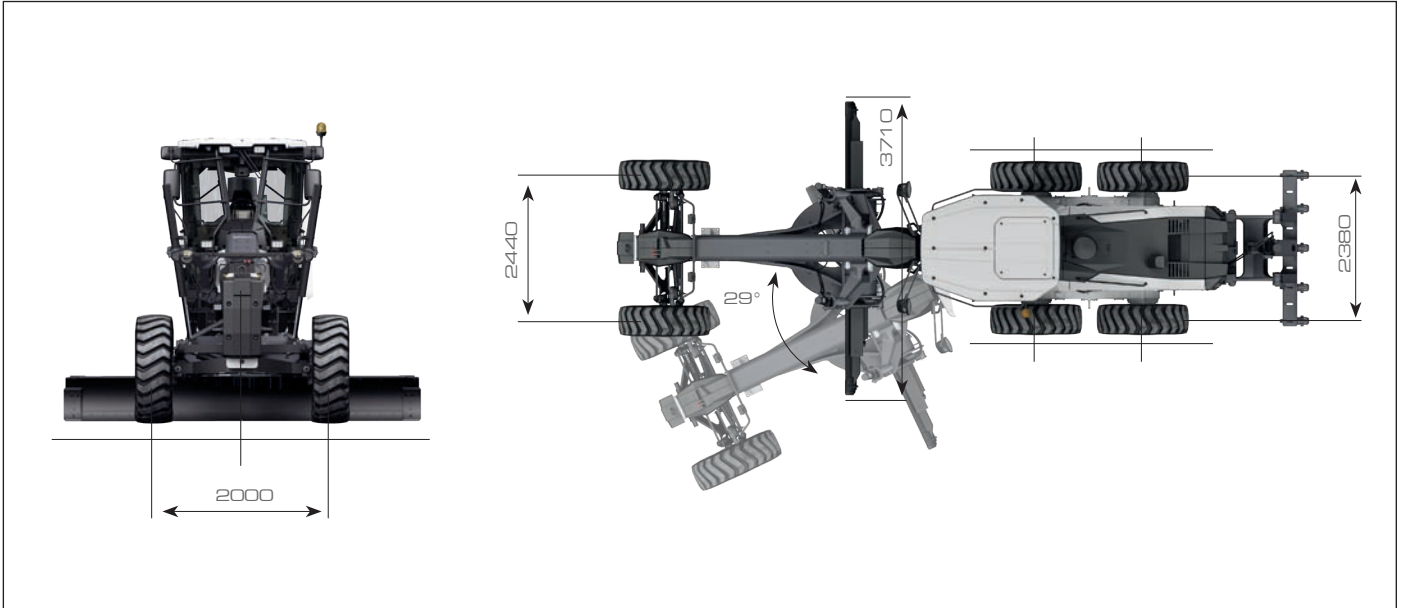

Dimensions (II)

Unit: mm

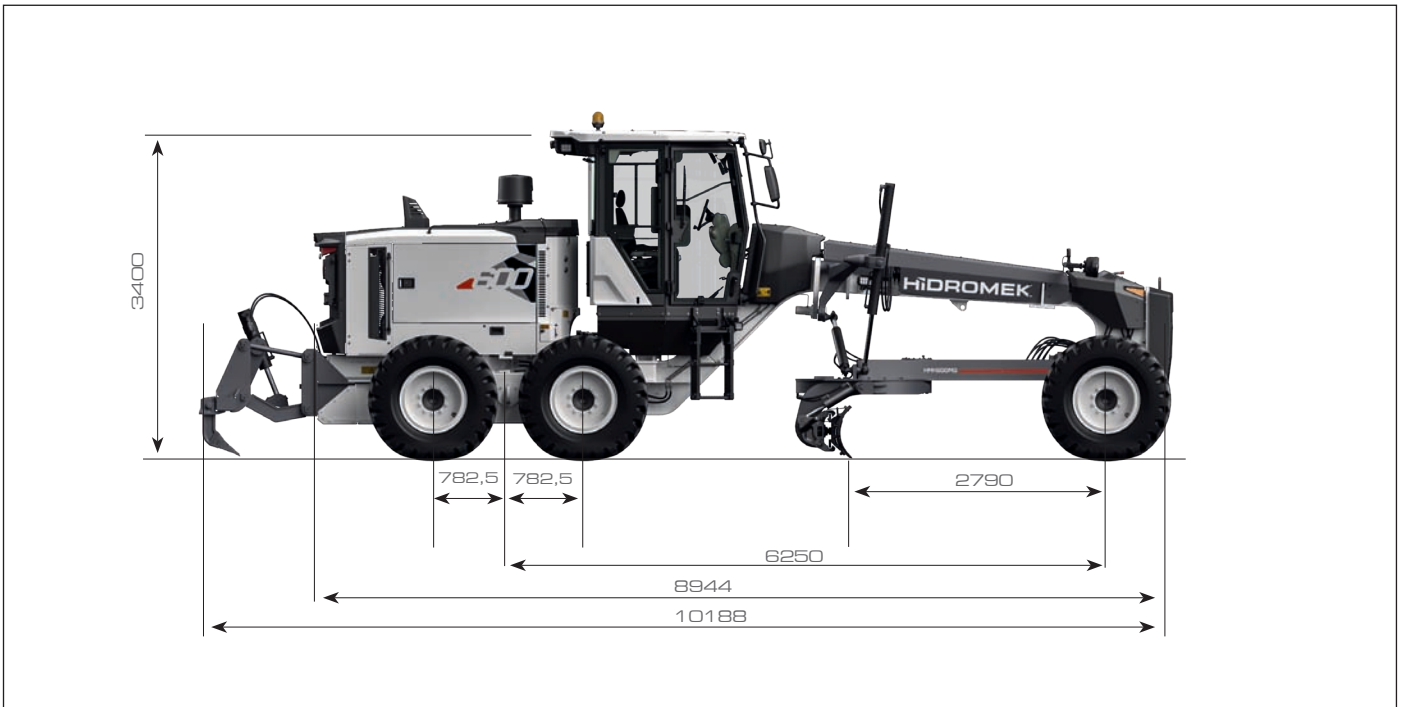

ENG - MARCH 2018

HIDROMEK®

HIDROMEK CONSTRUCTION EQUIPMENT (THAILAND) LTD.

Amata Nakorn Industrial Estate Phase 7, 700/699 Moo 1,
T. Phanthong, A. Phanthong, Chonburi 20160 Thailand
Phone: 66 (0) 38-447-349-54 Ext. 20 Fax: 66 (0) 38-447-355

FACTORY - HEAD OFFICE

Ayas yolu 25. km 1. Organize Sanayi Bölgesi Osmanlı Caddesi No: 1
06935 Sincan / ANKARA / TURKEY
Phone: (+90) 312 267 12 60 Fax: (+90) 312 267 21 18
www.hidromek.com

Notice:

- * HIDROMEK has the right to modify the specifications and design of the model indicated on this brochure without prior notice.
- * The equipment shown in the photos in this catalog includes some parts which are optional.